



**KR1 / KR3**



**Mechanical characteristics**

PARAMETER	
Housing	Self-extinguishing plastic UL 94 v0
Mounting	Front panel
Dimensions	78 x 35 x 78 mm (w x H x P)
Panel cut-out	71 x 29 (-0... +0.6 mm)
Weight	About 140 g
Terminals	24 terminals for cables from 2.5 mm <sup>2</sup> (AWG22.... AWG14): - on fixed or removable terminal block with screw terminals; - on terminal block with spring-load terminals
Protection degree	IP 65 mounted on the panel on the panel with gasket (IP20 for screw terminals) In conformity with En 60070-1 (only internal use)

**Electrical connections**

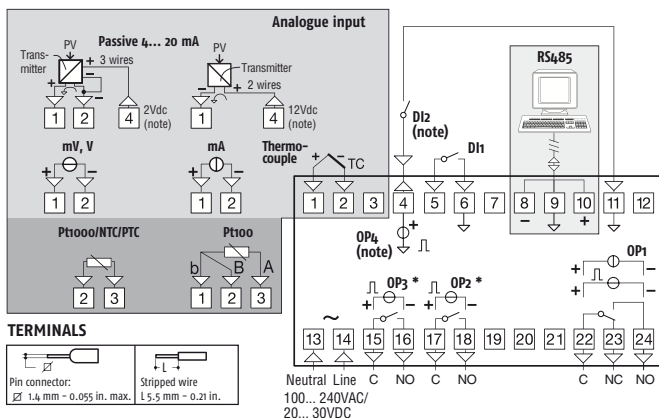

Note: Terminal 4 can be programmed as:  
 - Digital Input (DI2) connecting a free of voltage contact between terminals 4 and 11  
 - o... 12 V SSR Drive Output (OP4) connecting the load between terminals 4 and 11

**How to order**

**Model**  
 KR1 = Controller  
 KR1T = Controller+ timer  
 KR3 = Controller  
 KR3T = Controller+ timer  
 KR3P = Controller+ timer + programmer

**Power supply**  
 H = 100... 240 VAC  
 L = 24 VAC/DC

**Analogue input + digital input DI1 (standard)**  
 C = J, K, R, S, T, PT100, PT1000 (2 wires), mA, mV, V  
 E = J, K, R, S, T, NTC, PTC, mA, mV, V

**Output 1**  
 I = 4... 20 mA (KR3 only)  
 R = Relay SPDT 2 A (resistive load)  
 O = VDC for SSR

**Output 2**  
 - = Not available  
 R = Relay SPST 2 A (resistive load)  
 O = VDC for SSR  
 M = Relay SPST 2 A (servomotor drive KR3 only)(\*)

**Output 3**  
 - = Not available  
 R = Relay SPST 2 A (resistive load)  
 O = VDC for SSR  
 M = Relay SPST 2 A (servomotor drive KR3 only)(\*)

**Input/Output 4**  
 D = Output 4 (VDC for SSR)/Power transmitter/Dig. Input DI2

**Serial communication**  
 - = TTL Modbus  
 S = RS485 Modbus + TTL Modbus

**Connection type**  
 - = Standard (non-removable screw terminal block)  
 E = With removable screw terminal block  
 M = With removable spring terminal block  
 N = With removable terminal block (fixed part only)

\*: For servomotor drive, both **OUT2** and **OUT3** codes must be selected as "M".

**Dimensions (mm)**

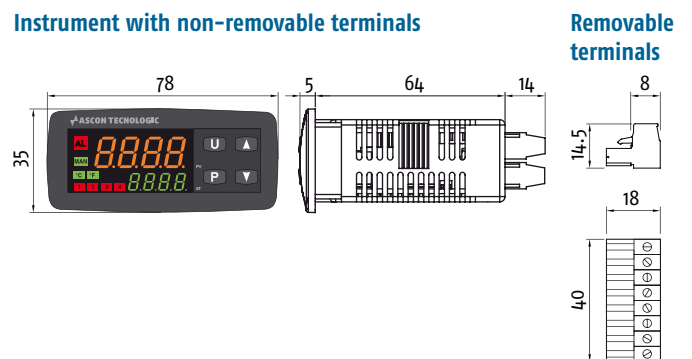

\*: For servomotor drive: **OUT2** = open, **OUT3** = close.

### 3 COLOUR DISPLAY

The colour of the main display changes depending on process value. Color change thresholds are programmable.

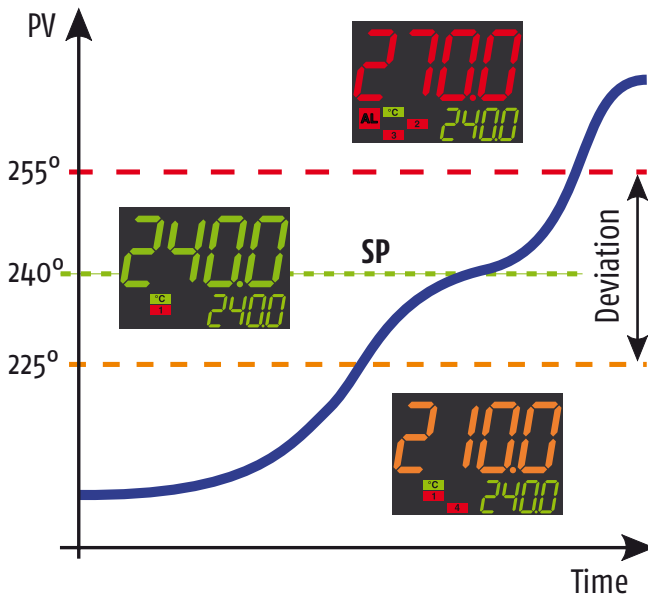

Immediate and intuitive process status acknowledgement, even at great distance.

This function may be disabled by the user.

### evoGREEN ENERGY SAVING

This user selectable function allows to reduce energy consumption while indicating the presence of alarms and process deviations, even from a great distance.

Once the function is activated, the display acts as follows:

- If no button is pressed within the user defined time, the display turns off and 4 display segments remain lit and alternate to report that the system is in operation;
- If an alarm is detected or a button is pressed, the display turns on again immediately.



Normal operation



Alarm or operator command

### evoTUNE

evoTune is a technological evolution of the "classic" auto-tuning method. Performs auto-tuning in all operating conditions.

At evoTune start-up the instrument evaluates the current situation (set point, current process measurements etc.) and establishes the best tuning solution.

Set point change made during auto-tuning, restarts process according to the new conditions.



### evoTOOLS CONFIGURATION CODE

To make a quick and safe instrument configuration of the instrument, just enter two 4 digit codes.

Input signal type, alarms, control mode and auxiliary functions activation will be selected and "ready to use" by pushing a few buttons.

This function does not exclude the full configuration menu, if the application requires it.



cod 1 = 0110

- 0 1: Type K thermocouple input;
- 10: Heat PID control, output on OP1, OP2 = AL1, OP3 = AL2, OP4 = AL3



cod 2 = 1284

- 1: AL1 Sensor break;
- 2: AL2 absolute high;
- 8: AL3 external band alarm;
- 4: Absolute working time counter (in hours)

### CUSTOMIZED PARAMETER SEQUENCE

Provide a user-defined operator interface has been, until now, a privilege of "custom" solutions.

The KUBE Line allows to customize operator parameters making safe and easy the instrument use.

## USER CALIBRATION

This function allows the manufacturer of the equipment to **calibrate the entire measurement values** compensating for errors due to:

- Sensor position;
- Sensor accuracy class;
- Accuracy of the instrument.

The "User calibration" **DOES NOT** change factory calibration and can be removed at any time.

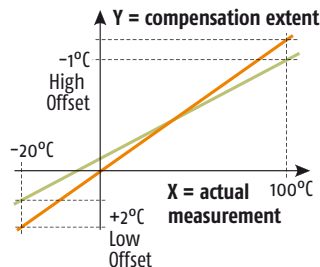

## WORKING HOURS/DAYS COUNTER

### With adjustable preset

Generates preventive maintenance alerts after a predetermined period of actual operation.

The alert does not interfere with instrument functions and can be reset by maintenance to restart the count.



Normal operation



Inspection request



Normal operation

### Non resettable

It counts the actual operation period, from its first power-up. Could be used to extend the warranty beyond the legal period. The continuous non-resettable counter provides manufacturer of the machine with a reliable parameter to calculate MTBF (Medium Time Between Failures).

## INDEPENDENT TIMER

Timer function with 6 different operation modes.

Programmable time base in h/min, min/s, s/thents of seconds.

Start/Hold/Reset command from digital inputs and/or from the button "⏏".

Function Timer operates in parallel but independently from Control.

## PROGRAMMER FUNCTION

This function allows to set:

- Up to 8 segments (4 ramps and 4 soaks);
- 4 start-up modes: at power-up, at power-up with initial delay, on command (from the keyboard, digital input or serial line) and on command signal with initial delay;
- 3 output modes at the end of the program: the process continues with the last programmed set-point, using the last active set-point, switching to stand-by;
- 2 programmable events for each program segment;
- Indicator "program running";
- Timed indicator "program end";
- Two digital inputs and/or the button "⏏" can be programmed to perform Start/Hold/Reset commands;

### Application example:

Paint booth and drying chambers to spray paint (car spray booths).

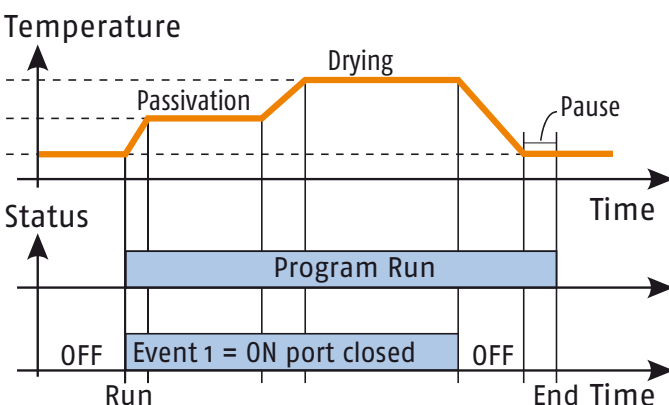

## ACCESSORIES

### A01 - Programming key

An electronic key, with memory, that can be connected directly to the instrument (even not powered), It provides a variety of functions, including:

- Memorize an instrument configuration (even not fully functional) and transfer it into another one;
- Configure the instruments in a safe and quick way, without the need for a PC;
- Communicate with a PC, even if the instrument is not equipped with an RS-485 port.



### Configuration software

Supplied free of charge, once loaded on PC, allows to:

- Easily configure an instrument;
- Upload and download previously saved configurations;
- Simplify the start-up, thanks to the real time update of variables and parameters.

### WinTec - Supervisor

Based on simple and flexible SCADA, it provides:

- Data acquisition;
- Centralized control;
- Alarm and recipes management;
- Trend;
- Report.

